

(19) World Intellectual Property Organization  
International Bureau



(43) International Publication Date  
27 December 2001 (27.12.2001)

PCT

(10) International Publication Number  
**WO 01/97908 A2**

- (51) International Patent Classification<sup>7</sup>: A61N 1/378, 1/36
- (74) Agents: WALDKOETTER, Eric, R. et al.; Medtronic, Inc., 710 Medtronic Parkway Northeast, Minneapolis, MN 55432 (US).
- (21) International Application Number: PCT/US01/18926
- (81) Designated States (*national*): AE, AL, AM, AT, AU, AZ, BA, BB, BG, BR, BY, CA, CH, CN, CR, CU, CZ, DE, DK, DM, EE, ES, FI, GB, GD, GE, GH, GM, HR, HU, ID, IL, IN, IS, JP, KE, KG, KP, KR, KZ, LC, LK, LR, LS, LT, LU, LV, MA, MD, MG, MK, MN, MW, MX, NO, NZ, PL, PT, RO, RU, SD, SE, SG, SI, SK, SL, TJ, TM, TR, TT, TZ, UA, UG, UZ, VN, YU, ZA, ZW.
- (22) International Filing Date: 13 June 2001 (13.06.2001)
- (84) Designated States (*regional*): ARIPO patent (GH, GM, KE, LS, MW, MZ, SD, SL, SZ, TZ, UG, ZW), Eurasian patent (AM, AZ, BY, KG, KZ, MD, RU, TJ, TM), European patent (AT, BE, CH, CY, DE, DK, ES, FI, FR, GB, GR, IE, IT, LU, MC, NL, PT, SE, TR), OAPI patent (BF, BJ, CF, CG, CI, CM, GA, GN, GW, ML, MR, NE, SN, TD, TG).
- (25) Filing Language: English
- (30) Priority Data:  
09/596,402 16 June 2000 (16.06.2000) US
- (71) Applicant: MEDTRONIC, INC. [US/US]; 710 Medtronic Parkway Northeast, Minneapolis, MN 55432 (US).
- (72) Inventors: JIMENEZ, Oscar; 1231 Medina Avenue, Coral Gables, FL 33134 (US). ECHARRI, Guillermo; 3031 Southwest 11th Street, Miami, FL 33135 (US). KAST, John, E.; 10815 140th Street North, Hugo, MN 55038 (US). RIEKELS, James, E.; 8616 Hopewood Lane North, New Hope, MN 55427 (US). SCHOMMER, Mark, E.; 9135 Kingsview Lane North, Maple Grove, MN 55369 (US).

**Published:**  
— without international search report and to be republished upon receipt of that report

*For two-letter codes and other abbreviations, refer to the "Guidance Notes on Codes and Abbreviations" appearing at the beginning of each regular issue of the PCT Gazette.*



**WO 01/97908 A2**

(54) Title: AN IMPLANTABLE MEDICAL DEVICE WITH AREGARDING COIL MAGNETIC SHIELD

(57) Abstract: A rechargeable implantable medical device with a magnetic shield placed on the distal side of a secondary recharging coil to improve recharging efficiency is disclosed. The rechargeable implantable medical device can be a wide variety of medical devices such as neuro stimulators, drug delivery pumps, pacemakers, defibrillators, diagnostic recorders, and cochlear implants. The implantable medical device has a secondary recharging coil carried over a magnetic shield and coupled to electronics and a rechargeable power source carried inside the housing. The electronics are configured to perform a medical therapy. Additionally a method for enhancing electromagnetic coupling during recharging of an implantable medical device is disclosed, and a method for reducing temperature rise during recharging of an implantable medical device is disclosed.

## **AN IMPLANTABLE MEDICAL DEVICE WITH A RECHARGING COIL MAGNETIC SHIELD**

### **BACKGROUND OF THE INVENTION**

This disclosure relates to an implantable medical device and more specifically a rechargeable implantable medical device that produces a medical therapy.

The medical device industry produces a wide variety of electronic and mechanical devices for treating patient medical conditions. Depending upon medical condition, medical devices can be surgically implanted or connected externally to the patient receiving treatment. Clinicians use medical devices alone or in combination with drug therapies and surgery to treat patient medical conditions. For some medical conditions, medical devices provide the best, and sometimes the only, therapy to restore an individual to a more healthful condition and a fuller life. Examples of implantable medical devices include neuro stimulators, drug delivery pumps, pacemakers, defibrillators, diagnostic recorders, and cochlear implants. Some implantable medical devices provide therapies with significant power demands. To reduce the size of the power source and to extend the life of the power source, some of these implantable device can be recharged while implanted with a transcutaneous recharge signal produced by a primary coil.

Implantable medical devices configured for recharging are typically configured with either the recharging coil internal to the medical device housing, external to the housing, or remotely located away from the housing. However the medical device recharging coil is configured, it is desirable to improve recharging efficiency for benefits such as decreased recharging time and decreased medical device temperature rise while recharging.

For the foregoing reasons there is a need for a rechargeable implantable medical device with improved recharging efficiency.

### **SUMMARY OF THE INVENTION**

Improved recharging efficiency for a rechargeable implantable medical device is accomplished with a magnetic shield placed on the secondary recharging coil distal side. The secondary recharging coil is coupled to electronics and a rechargeable power source carried inside the housing. The electronics are configured to perform a medical therapy.

In one embodiment, an external secondary recharging coil is carried on the housing exterior, and the magnetic shield is placed between the recharging coil distal side and the housing proximal side. In another embodiment, a remote secondary recharging coil is placed away from the housing, and the magnetic shield is placed on the distal side of the secondary recharging coil. In another embodiment, secondary recharging coil is internal, and the magnetic shield is placed on the distal side of the secondary recharging coil between the secondary recharging coil and the electronics.

#### **BRIEF DESCRIPTION OF THE DRAWINGS**

- FIG. 1 shows an environment of a rechargeable implantable medical device;
- FIG. 2 shows a rechargeable implantable medical device neuro stimulator embodiment;
- FIG. 3 shows a neuro stimulator electronics block diagram embodiment;
- FIG. 4a shows a rechargeable implantable medical device with external secondary recharging coil block diagram embodiment;
- FIG. 4b shows rechargeable implantable medical device with remote external secondary recharging coil block diagram embodiment;
- FIG. 4c shows rechargeable implantable medical device with internal secondary recharging coil block diagram embodiment;
- FIG. 5 shows an exploded view of a neuro stimulator embodiment;
- FIG. 6 shows an exploded view of a magnetic shield embodiment;
- FIG. 7 shows a side view of a neuro stimulator embodiment;
- FIG. 8a shows a neuro stimulator with remote secondary recharging coil embodiment;
- FIG. 8b shows an exploded view of the remote secondary recharging coil embodiment;
- FIG. 9a shows a simulation test configuration with a magnetic shield under a secondary recharging coil;
- FIG. 9b shows a simulation test configuration with a magnetic covering the medical device housing;
- FIG. 10a shows simulation results without a magnetic shield of power transfer signal flux lines;

- FIG. 10b shows simulation results with a magnetic shield under a secondary recharging coil of power transfer signal flux lines;
- FIG. 10c shows simulation results with a magnetic shield covering the medical device housing of power transfer signal flux lines;
- FIG. 11 shows a flowchart of a method for enhancing electromagnetic coupling of an implantable medical device with recharge coil embodiment; and,
- FIG. 12 shows a flowchart of a method for reducing temperature rise of an implantable medical device with recharging coil embodiment.

### **DETAILED DESCRIPTION OF THE PREFERRED EMBODIMENTS**

FIG. 1 shows the general environment of one rechargeable implantable medical device 20 embodiment. An implantable neuro stimulator 22 is shown in FIG. 1, but other embodiments such as drug delivery pumps, pacemakers, defibrillators, diagnostic recorders, cochlear implants, and the like are also applicable. Implantable medical devices 20 are often implanted subcutaneously approximately one centimeter below the surface of the skin with an electrical lead 24 or catheter extending to one or more therapy sites. The rechargeable implantable medical device 20 is recharged with a recharging device 28 such as a patient charger or programmer that also has a charging capability.

Recharging an implanted medical device 20 generally begins with placing a recharging head 30 containing a primary recharging coil 34 against the patient's skin near the proximal side of the medical device 20. Some rechargers 28 have an antenna locator that indicates when the recharge head 30 is aligned closely enough with the implanted medical device 20 for adequate inductive charge coupling. The recharge power transfer signal is typically a frequency that will penetrate transcutaneous to the location of the implanted medical device 20 such as a frequency in the range from 5.0 KHz to 10.0 KHz. The power transfer signal is converted by the implantable medical device 20 into regulated DC power that is used to charge a rechargeable power source 34. Telemetry can also be conducted between the recharger 28 and the implanted medical device 20 during recharging. Telemetry can be used to aid in aligning the recharger 28 with the implanted medical device 20, and telemetry can be used to manage the recharging process. Telemetry is typically conducted at a frequency in the range from 150 KHz to 200 KHz

using a medical device telemetry protocol. For telemetry, the recharger 28 and implanted medical device 20 typically have a separate telemetry coil. Although, the recharging coil can be multiplexed to also serve as a telemetry coil.

FIG. 2 shows a rechargeable neuro stimulator 22 with a lead extension 36 and a lead 24 having electrical contacts 38 embodiment. FIG. 3 shows a neuro stimulator electronics 40 block diagram embodiment. The neuro stimulator 22 generates a programmable electrical stimulation signal. The neuro stimulator electronics 40 comprises a processor 44 with an oscillator 46, a calendar clock 48, memory 50, and system reset 52, a telemetry module 54, a recharge module 56, a power source 58, a power management module 60, a therapy module 62, and a therapy measurement module 64. All components of the neuro stimulator 22 are contained within or carried on the housing 66.

FIGS. 4a-4c show an implantable medical device 20 with recharging coil block diagrams. The implantable medical device 20 with external recharging coil magnetic shield comprises a housing 66, electronics 40, a rechargeable power source 58, a secondary recharging coil 68, and a magnetic shield 70. The housing 66 has an interior cavity 72, an exterior surface 74, a proximal face 76, a therapy connection 78, and a recharge feedthrough 80. The therapy connection 78 can be any type of therapy connection 78 such as a stimulation feedthrough, a drug infusion port, or a physiological sensor. There can also be more than one therapy connection 78 and a combination of different types of therapy connections 78. The housing 66 is hermetically sealed and manufactured from a biocompatible material such as titanium, epoxy, ceramic, and the like. The housing 66 contains electronics 40.

The electronics 40 are carried in the housing interior cavity 72 and configured to perform a medical therapy. The electronics 40 are electrically connected to both a therapy module therapy connection 78 and the recharge feedthrough 80. The rechargeable power source 58 is carried in the housing interior cavity 72 and coupled to the electronics 40. The rechargeable power source 58 can be a physical power source such as a spring, an electrical power source such as a capacitor, or a chemical power source such as a battery. The battery can be a hermetically sealed rechargeable battery such as a lithium ion (Li+) battery and the like. The electronics 40 are coupled to the secondary recharging coil 68.

The secondary recharging coil 68 is coupled to the electronics 40 and can also be coupled to the rechargeable power source 58 in addition to the electronics 40. In various embodiments the secondary recharging coil 68 can be located on the housing proximal face 76, inside the housing 66, and remotely away from the housing 66. The secondary recharging coil 68 has a proximal side implanted toward a patient's skin and a distal side implanted toward a patient's internal organs. The secondary recharging coil 68 is manufactured from a material with electromagnetic properties such as copper wire, copper magnet wire, copper litz woven wire, gold alloy or the like. The secondary recharging coil 68 can be manufactured from a wide variety of sizes such as wire diameters in the range from about 0.016 cm (34 AWG, American Wire Gauge) to about 0.040 cm (26 AWG), or any other suitable diameter. The secondary recharging coil 68 is coupled to the recharging feedthroughs 80 with an electrical connection 86. The electrical connection 86 is protected with a hermetic seal to prevent the electrical connection 86 from being exposed to biological tissue or fluids. The hermetic seal is a biocompatible material and can take many forms including potting material, polymer encapsulation, coil cover with polymer seal, or the like.

The embodiment in FIG. 4a has a secondary recharging coil 68 carried on the proximal face 76 of the implantable medical device 20 with the magnetic shield 70 positioned between the secondary recharging coil 68 and the proximal face 76. The external secondary recharging coil 68 increases recharge efficiency because the secondary recharging coil 68 is located just under the surface of the skin to decrease coupling distance, and the magnetic shield 70 is positioned to both attract flux lines to the area of the secondary recharging coil 68 and reduce flux lines from coupling into the housing 66 to reduce eddy currents in the housing 66. The embodiment in FIG. 4b has an internal secondary recharging coil 68 with the magnetic shield 70 positioned between the internal secondary recharging coil 68 and the electronics 40. The internal secondary recharging coil 68 reduces manufacturing complexity and the magnetic shield 70 improves coupling and reduces eddy currents induced into the electronics 40. The embodiment in FIG. 4c has a remote secondary recharging coil 68 located away from the housing 66 with the magnetic shield 70 positioned on the distal side of the secondary recharging coil 68. The

remote secondary recharging coil 68 permits the clinician more positioning options while the magnetic shield 70 improves coupling.

FIG. 5 shows an embodiment of a neuro stimulator 22 with some external components exploded away from the housing 66. The external components include a coil cover 88, a secondary recharging coil 68, and a magnetic shield 70. The magnetic shield 70 is positioned between the secondary recharging coil 68 and the housing 66. The magnetic shield 70 is typically configured to cover at least the footprint of the secondary recharging coil 68 on the implantable medical device housing 66, and the magnetic shield 70 can be configured to cover the proximal face 76 of the medical device 20 or most or all of the implantable medical device 20. The magnetic shield 70 is manufactured from a material with high magnetic permeability such as amorphous metal film, amorphous metal fibers, a magnetic alloy, ferrite materials, and the like. Amorphous metal has a disordered atomic structure and some compositions such as Co-Fe-Si-B have high permeability and near zero magnetostriction. Commercially available materials that are suitable for a magnetic shield include Honeywell Metglas amorphous foil 2714A and Unitika Sency™ amorphous metal fiber. The magnetic shield 70 is configured with a thickness suitable for the application such as in the range from about 0.0254 centimeters (0.001 inch) to 0.0101 centimeters (0.004 inch) thick. The magnetic shield 70 can be configured with eddy cuts 90 to reduce perpendicular magnetic flux induced eddy current flow in the magnetic shield itself. Eddy cuts 90 can be configured with dimensions and placement suitable for the application such as with a width in the range from 0.0025 centimeters (0.001 inch) to 0.0508 centimeters (0.02 inch) in width configured in a radial pattern on the magnetic shield 70. The eddy cuts 90 can be formed with a variety of manufacturing processes such as laser cutting, die cutting, and chemical etching. The magnetic shield 70 can also be shaped to meet geometry requirements of the implantable medical device 20 such as with a central opening 92 to facilitate placement of the secondary recharge coil 68.

The magnetic shield 70 can be configured with more than one magnetic shield 70 positioned between the secondary recharge coil 68 and the implantable medical device housing 66 to reduce eddy currents induced by radial magnetic flux. Multiple magnetic shields 70 can be used to constrain eddy currents to an individual magnetic shield 70 or for

other manufacturing reasons. To aid in constraining eddy currents to an individual magnetic shield 70, an insulator 94 can be placed between the magnetic shields 70. The insulator is a material with good electrical insulating properties such as plastic, mylar, polyimide, insulating tape, insulating adhesive, and the like.

FIG. 6 shows a multiple magnetic shield 70 embodiment. An insulating sheet 94 separates the magnetic shields 70. Multiple magnetic shields 70 improve magnetic shielding while reducing the formation of eddy currents in the magnetic shield 70 itself. The insulating sheet 94 is a material with good insulating qualities suitable for placement between magnetic shields 70 such as plastic, mylar, polyimide, insulating tape, insulating adhesive, and the like. FIG. 7 shows a side view of a neuro stimulator 22 embodiment. FIG. 8a shows a neuro stimulator 22 with remote secondary recharging coil 68 embodiment, and FIG. 8b shows an exploded view of the remote secondary recharging coil 68 embodiment.

FIG. 9a shows a simulation test configuration with a magnetic shield 70 under a secondary recharging coil 68, and FIG. 9b shows a simulation test configuration with a magnetic shield 70 covering the medical device housing 66. FIGS. 9a and 9b are not to scale. Both simulation test configurations were done using two dimensional finite element analysis magnetic modeling software such as that available from MagSoft located in Troy, New York. Also both simulation test configurations used the following parameters. The primary recharging coil 34 has 250 turns of 0.051 cm diameter (24 AWG) magnet wire with an outer diameter of 4.572 cm (1.8 inches) and an inner diameter of 2.019 cm (0.795 inches) with a Toroidal magnetic core in the center having an effective relative permeability  $\mu_r$  of 10. The secondary recharging coil 68 has 200 turns of 0.025 cm diameter (30 AWG) magnet wire forming a coil with an outer diameter of 3.302 cm (1.30 inches) and an inner diameter of 0.635 cm (0.25 inch). The medical device housing 66 is titanium having a thickness of 0.030 cm (0.012 inch). The separation between the primary recharging coil 34 and the secondary recharging coil 68 is 1.0 cm (0.394 inch). The recharge power transfer signal is 150 VAC peak-to-peak at 8.0 KHz. The magnetic shield 70 in FIG. 9a is composed of alternating 0.002 cm (.001 inch) thick layers of Metglass and air gap with the secondary recharging coil 68 located 0.013 cm (0.005 inch) above the magnetic shield 70. The magnetic shield 70 in FIG. 9b has the magnetic shield 70



described for FIG. 9a and in addition a similar magnetic shield 70 covering the medical device 20 sides and bottom.

FIG. 10a shows simulation results without a magnetic shield 70 of power transfer signal flux lines 96 interacting with a secondary recharging coil 68 and a medical device housing 66. Power loss in the medical device housing 66 is 0.430 Watts and the coupling efficiency is 12.3 %. For this simulation, the magnetic shield 70 shown in FIG. 9a was removed.

FIG. 10b shows simulation results with a magnetic shield 70 placed under the secondary recharging coil 68 and power transfer signal flux lines 96 interacting with the secondary recharging coil 68 and a medical device housing 66. Power loss in the medical device housing 66 is 0.143 Watts and the coupling efficiency is 25.4 %. The simulation results show improved recharging efficiency through enhanced electromagnetic coupling between the secondary recharging coil 68 and a primary recharging coil 34. The improved electromagnetic coupling between the primary recharging coil 34 can be in the range from about 10% to 28% coupling efficiency at about one centimeter. Electromagnetic coupling efficiency is calculated with the following equation:  $Coupling\ Efficiency = \frac{P_{out}}{P_{in}} \times 100\%$

where  $P_{out}$  is measured at the secondary recharging coil 68 and  $P_{in}$  is measured at the primary recharging coil 34. The recharging efficiency is also improved through reduced eddy currents in the housing 66. Reducing eddy currents during recharging also reduces medical device 22 temperature rise during recharging for improved safety.

FIG. 10c shows simulation results with a magnetic shield 70 covering the medical device housing 66. Power loss in the medical device housing 66 is 0.38 mWatts and the coupling efficiency is 27.5 %. The simulation results show improved recharging efficiency over the simulation in FIG. 10b. The recharging efficiency is also improved through reduced eddy currents in the housing 66. Reducing eddy currents during recharging also reduces medical device 20 temperature rise during recharging for improved safety.

FIG. 11 shows a method for enhancing electromagnetic coupling of an implantable medical device external recharging coil embodiment. Positioning a secondary recharging coil 98 in operational relationship to an implantable medical device 20. Positioning a

magnetic shield 100 on the distal side of the secondary recharging coil 68. Attracting electromagnetic flux lines 102 from a primary recharging coil 34 to the secondary recharging coil 68 with the magnetic shield 70. Improving electromagnetic coupling between a primary recharging coil 34 and a secondary recharging coil 68. The improved electromagnetic coupling 104 between the primary recharging coil 34 and the secondary recharging coil 68 is in the range from about 10% to 28% coupling efficiency at about one centimeter. Improving efficiency 106 of energy transfer from the primary recharging coil 34 to the secondary recharging coil 68. The efficiency of energy transfer is improved because less energy is lost to eddy currents in the housing 66.

FIG. 12 shows a method for method for enhancing electromagnetic coupling of an implantable medical device external recharge coil embodiment. Positioning a secondary recharging coil 98 in operational relationship to an implantable medical device 20. Positioning a magnetic shield 100 on the distal side of the secondary recharging coil 68. Reducing electromagnetic flux lines 108 that couple with the housing 66, or electronics 40 carried within the housing 66, or both the housing 66 and electronics 40. Reducing eddy currents 110 in the housing 66 caused by electromagnetic flux lines that couple with the housing 66, or eddy currents in the electronics 40 carried within the housing 66, or both the housing 66 and electronics 40. Reducing temperature rise 112 during recharging because of reduced eddy currents in the housing 66. The implantable medical device 20 temperature rise during recharging is typically controlled to less than about two degrees Centigrade above surround tissue temperature.

Thus, embodiments of an implantable medical device 20 with a recharging coil magnetic shield 70 are disclosed to improve recharging efficiency and many other advantages apparent from the claims. One skilled in the art will appreciate that the present invention can be practiced with embodiments other than those disclosed. The disclosed embodiments are presented for purposes of illustration and not limitation, and the present invention is limited only by the claims that follow.

What is claimed is:

1. An implantable medical device with efficient recharging coil, comprising:  
a housing having an interior cavity, a proximal face, and an electrical feedthrough;  
electronics carried in the housing interior cavity and configured to perform a  
medical therapy;  
a rechargeable power source carried in the housing interior cavity and coupled to  
the electronics;  
a secondary recharging coil coupled to the electronics and rechargeable power  
source, the secondary recharging coil having a distal side; and,  
a magnetic shield placed on a distal side of the receiving recharging coil to  
improve recharging efficiency.
2. The implantable medical device as in claim 1 wherein the magnetic shield  
improves recharging efficiency by improving electromagnetic coupling between  
the secondary recharging coil and a primary recharging coil.
3. The implantable medical device as in claim 2 wherein recharging efficiency is  
improved by increasing flux lines that couple with the receiving recharging coil  
from the primary recharging coil.
4. The implantable medical device as in claim 2 wherein the improved  
electromagnetic coupling is greater than 10 percent coupling efficiency at about  
one centimeter.
5. The implantable medical device as in claim 1 wherein recharging efficiency is  
improved by decreasing flux lines that couple with the housing.
6. The implantable medical device as in claim 5 wherein recharging efficiency is  
improved through reduced eddy currents in the housing.
7. The implantable medical device as in claim 6 wherein reduced eddy currents  
during recharging also reduces medical device temperature rise during recharging.
8. The implantable medical device as in claim 7 wherein the temperature rise of the  
implantable medical device during recharging is less than two degrees Celsius.
9. The implantable medical device as in claim 9 wherein the magnetic shield is  
located between the secondary recharging coil and the electronics.

10. The implantable medical device as in claim 1 wherein the magnetic shield is a material with high magnetic permeability.
11. The implantable medical device as in claim 10 wherein the magnetic shield is selected from the group consisting of: amorphous metal film, amorphous metal wire, and magnetic alloy.
12. The implantable medical device as in claim 1 wherein the magnetic shield includes eddy cuts to reduce eddy current flow through the magnetic shield.
13. The implantable medical device as in claim 1 wherein the magnetic shield has a central opening.
14. The implantable medical device as in claim 1, further comprising a first insulator placed between a first magnetic shield and a second magnetic shield.
15. The implantable medical device as in claim 14, further comprising a second insulator placed between a second magnetic shield and a third magnetic shield.
16. The implantable medical device as in claim 14 wherein the first insulator and a second insulator are selected from the group consisting of: plastic, mylar, and tape.
17. The implantable medical device as in claim 1 wherein the secondary recharging coil is carried on the proximal face of the housing and the magnetic shield is placed between the receiving recharging coil and the proximal face of the housing.
18. The implantable medical device as in claim 1 wherein the secondary recharging coil is an external secondary recharging coil located away from the housing.
19. The implantable medical device as in claim 1 wherein the receiving recharging coil is located in the housing interior cavity.
20. The implantable medical device as in claim 1 wherein the housing is an electric conductor.
21. The implantable medical device as in claim 15 wherein the housing is selected from the group consisting of: titanium, ceramic, and epoxy.
22. The implantable medical device as in claim 1 wherein the medical device is selected from the group consisting of: neuro stimulators, pacemakers, defibrillators, drug delivery pumps, diagnostic recorders, and cochlear implants.

23. An implantable medical device with efficient recharging coil, comprising:  
a housing having an interior cavity, a proximal face, and at least one electrical feedthrough;  
electronics carried in the housing interior cavity and configured to perform a medical therapy;  
a rechargeable power source carried in the housing interior cavity and coupled to the electronics;  
a receiving recharging coil coupled to the electronics and rechargeable power source; and,  
a means for improving recharging efficiency placed on a distal side of the secondary recharging coil.
24. The implantable medical device as in claim 23 wherein recharging efficiency is improved by increasing flux lines that couple with the receiving recharging coil.
25. The implantable medical device as in claim 23 wherein recharging efficiency is improved by decreasing flux lines that couple with the housing.
26. An efficient recharging coil for an implantable medical device, comprising:  
a secondary recharging coil having at least two leads coupleable to an implantable medical device; and,  
a magnetic shield configured to be positioned on a distal side of the secondary recharging coil.
27. The implantable medical device as in claim 1 wherein the magnetic shield is a material with high magnetic permeability.
28. The efficient recharging coil as in claim 26, wherein the secondary recharging coil is positioned on an external surface of a housing and the magnetic shield is positioned between the secondary recharging coil and the external surface of the housing.
29. The efficient recharging coil as in claim 26, further comprising an insulator placed between a first magnetic shield and a second magnetic shield.
30. A method of enhancing electromagnetic coupling of an implantable medical device recharging coil, comprising:

positioning a secondary recharging coil in operational relationship to an implantable medical device;  
positioning a magnetic shield on a distal side of the secondary recharging coil;  
attracting electromagnetic flux lines from a primary recharging coil to the secondary recharging coil with the magnetic shield; and,  
improving electromagnetic coupling between a primary recharging coil and a secondary recharging coil; and,  
improving efficiency of energy transfer from the primary recharging coil to the secondary recharging coil.

31. The implantable medical device as in claim 1 wherein recharging efficiency is improved through enhanced electromagnetic coupling between the secondary recharging coil and a primary recharging coil.
32. The implantable medical device as in claim 2 wherein the enhanced electromagnetic coupling is greater than 10 percent coupling efficiency at about one centimeter.
33. The implantable medical device as in claim 1 wherein the magnetic shield is a material with high magnetic permeability.
34. The implantable medical device as in claim 11 wherein the magnetic shield is selected from the group consisting of: amorphous metal film, amorphous metal wire, and magnetic alloy.
35. The implantable medical device as in claim 1 wherein the secondary recharging coil is carried on the proximal face of the housing and the magnetic shield is placed between the receiving recharging coil and the proximal face of the housing.
36. The implantable medical device as in claim 1 wherein the secondary recharging coil is an external secondary recharging coil located away from the housing.
37. The implantable medical device as in claim 1 wherein the medical device is selected from the group consisting of: neuro stimulators, pacemakers, defibrillators, drug delivery pumps, diagnostic recorders, and cochlear implants.
38. A method of reducing temperature rise during recharging of an implantable medical device external recharging coil, comprising:

positioning a secondary recharging coil in operational relationship to an implantable medical device;  
positioning a magnetic shield on a distal side of the secondary recharging coil;  
reducing electromagnetic flux lines that couple with the housing;  
reducing eddy currents in the housing caused by electromagnetic flux lines that couple with the housing; and,  
reducing temperature rise during recharging because of reduced eddy currents in the housing.

39. The implantable medical device as in claim 1 wherein recharging efficiency is improved by decreasing flux lines that couple with the housing.
40. The implantable medical device as in claim 5 wherein recharging efficiency is improved through reduced eddy currents in the housing.
41. The implantable medical device as in claim 6 wherein reduced eddy currents during recharging also reduces medical device temperature rise during recharging.
42. The implantable medical device as in claim 7 wherein the temperature rise of the implantable medical device during recharging is less than two degrees Celsius.
43. The implantable medical device as in claim 1 wherein the magnetic shield is a material with high magnetic permeability.
44. The implantable medical device as in claim 11 wherein the magnetic shield is selected from the group consisting of: amorphous metal film, amorphous metal wire, and magnetic alloy.
45. The implantable medical device as in claim 1 wherein the medical device is selected from the group consisting of: neuro stimulators, pacemakers, defibrillators, drug delivery pumps, diagnostic recorders, and cochlear implants.

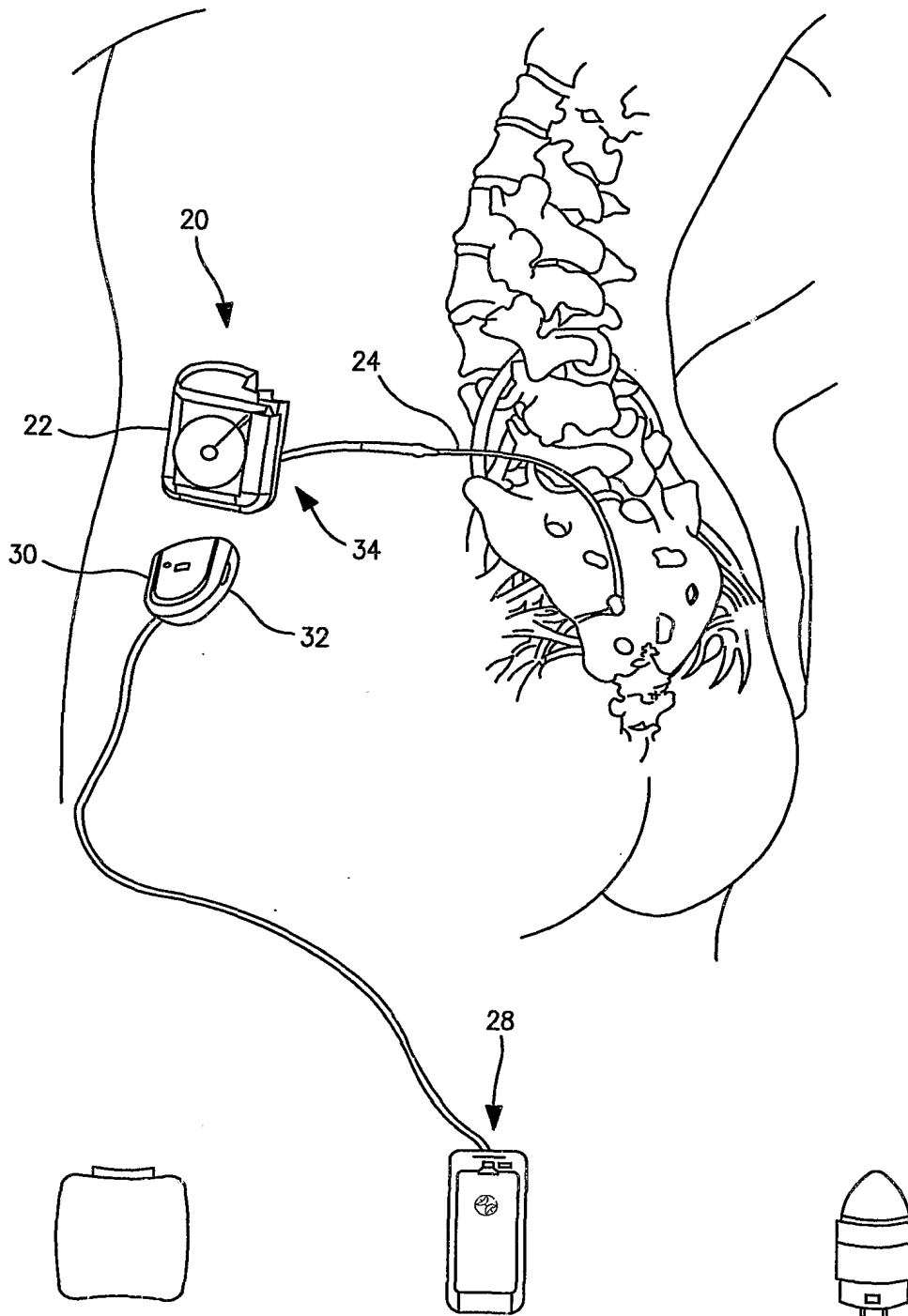

FIG. 1



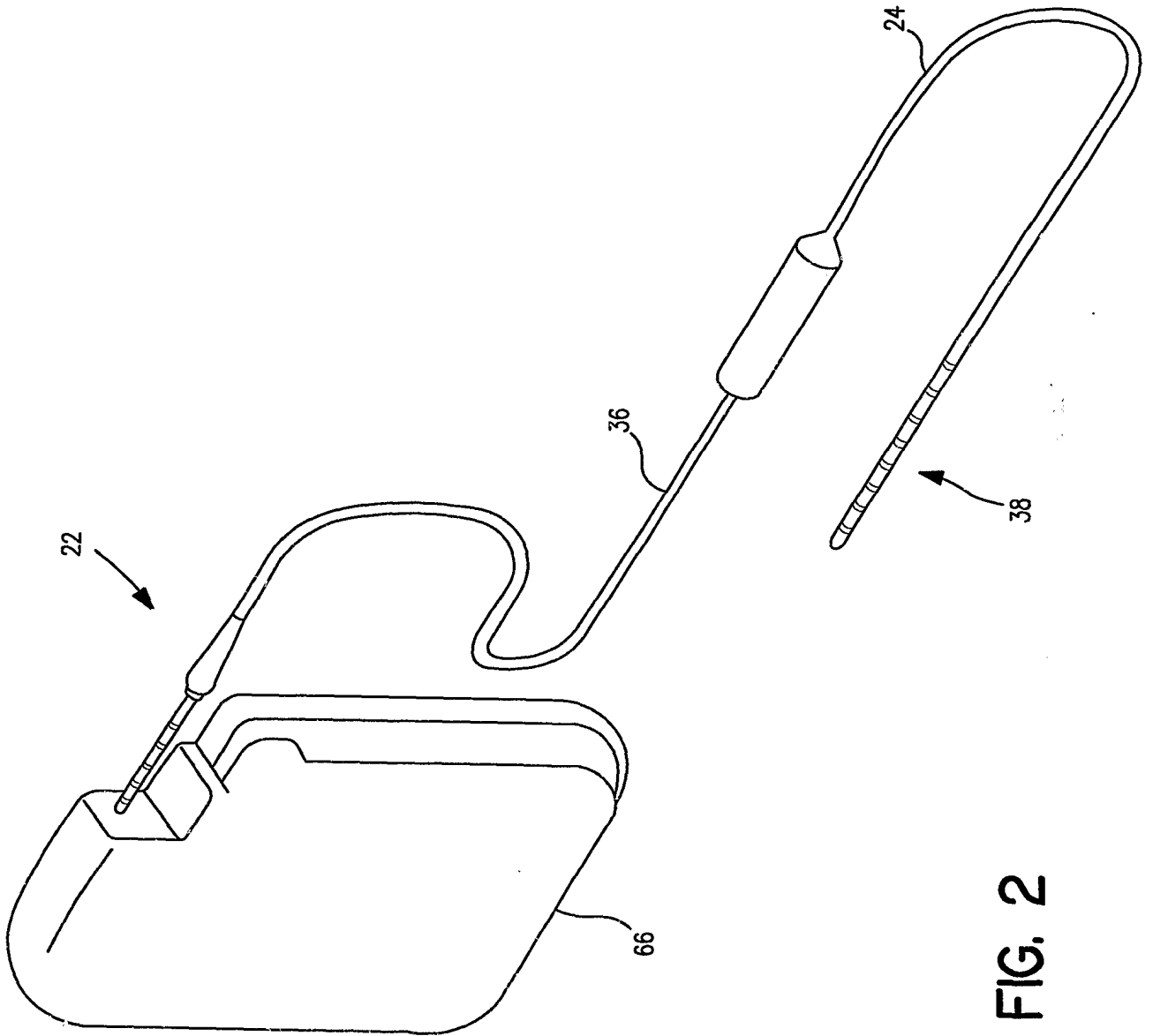

FIG. 2

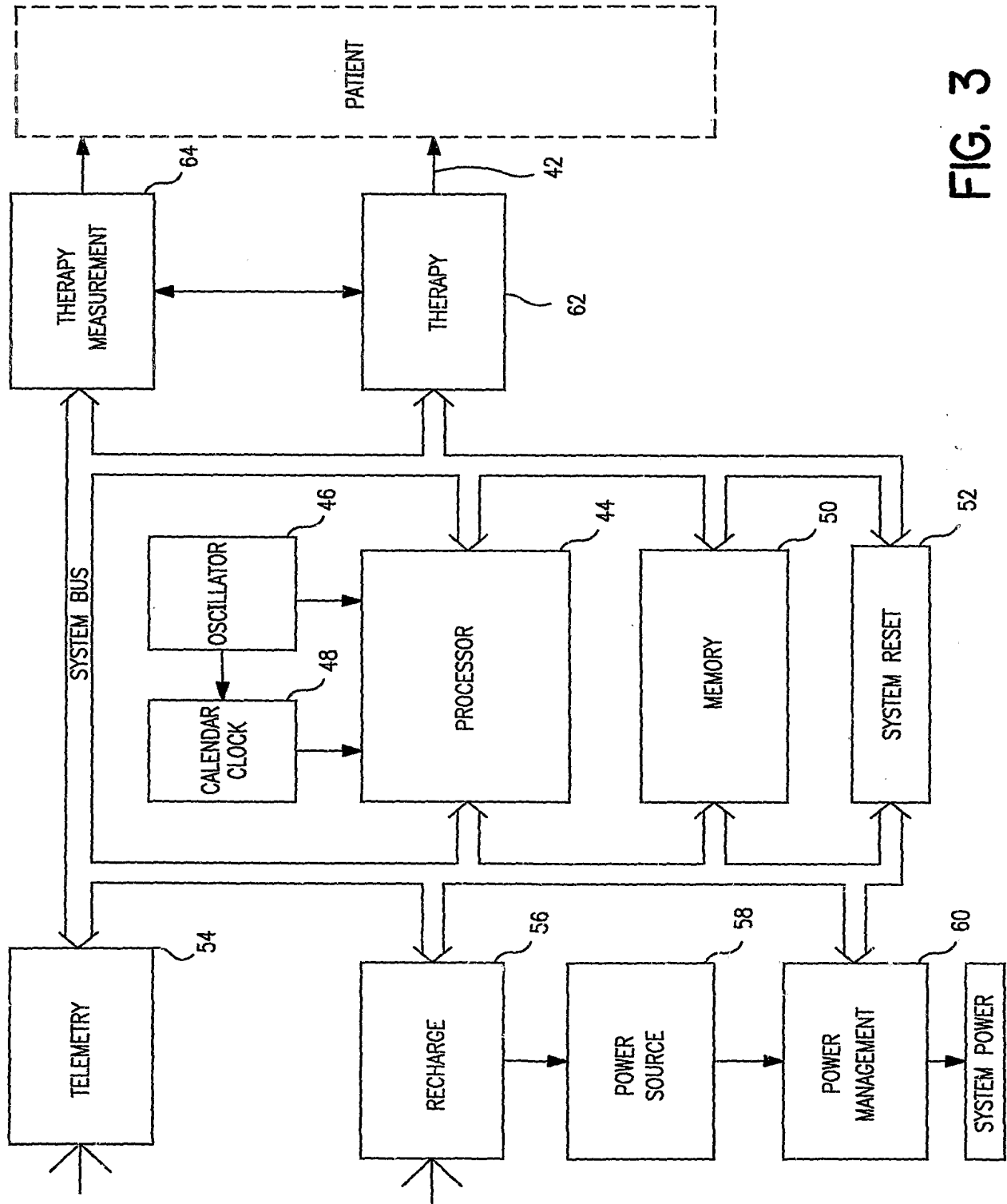

FIG. 3

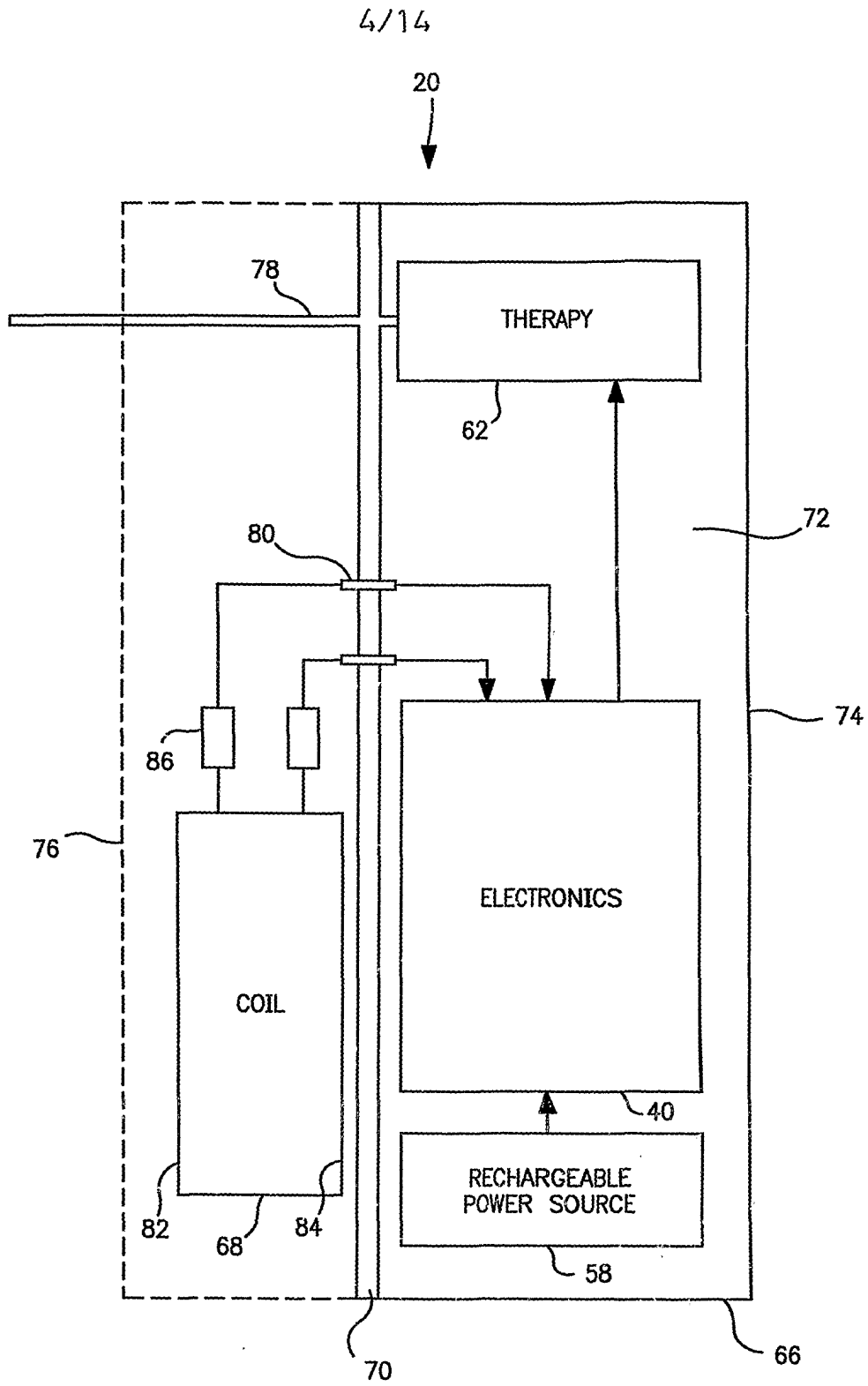

FIG. 4a

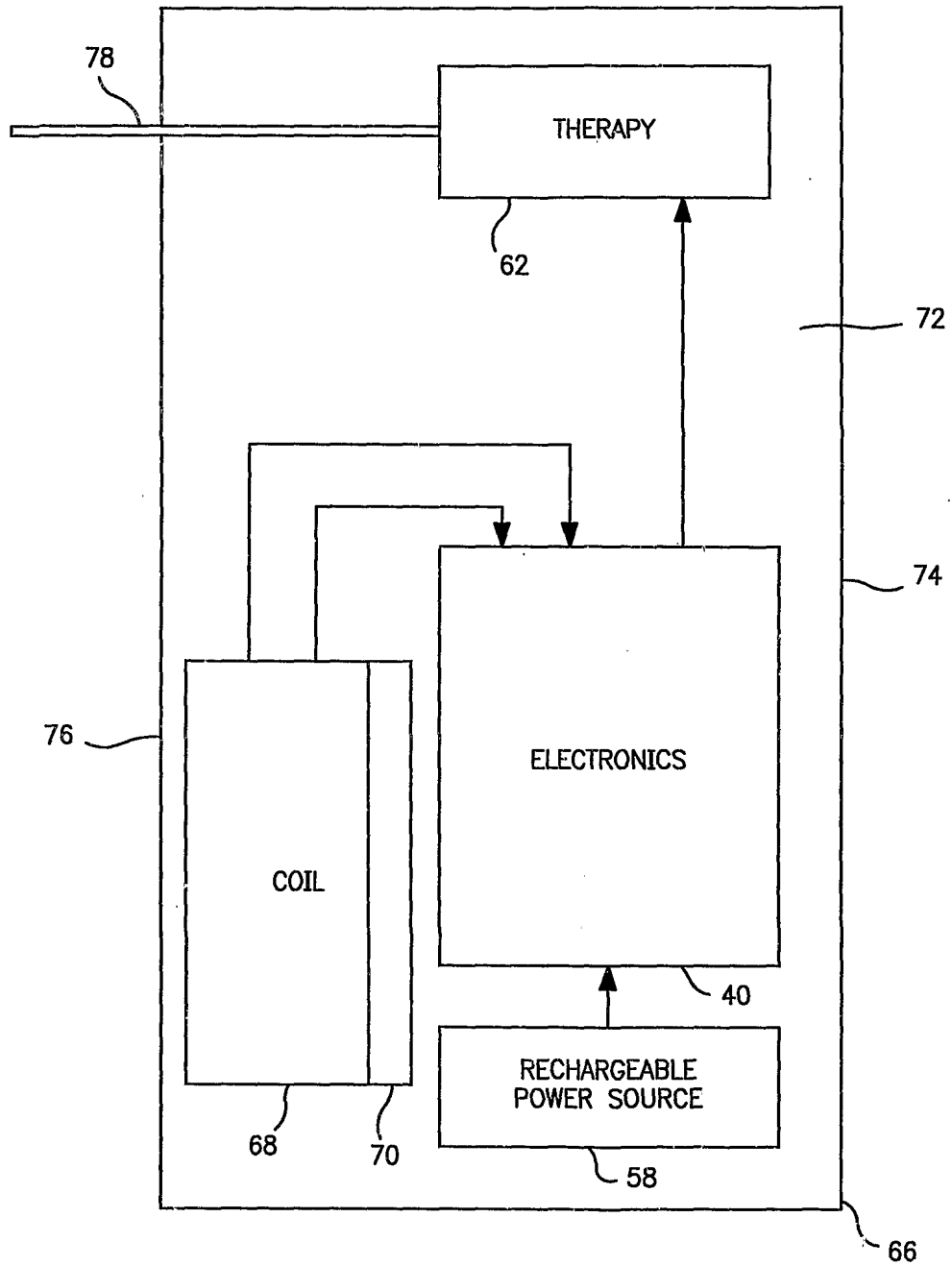

FIG. 4b

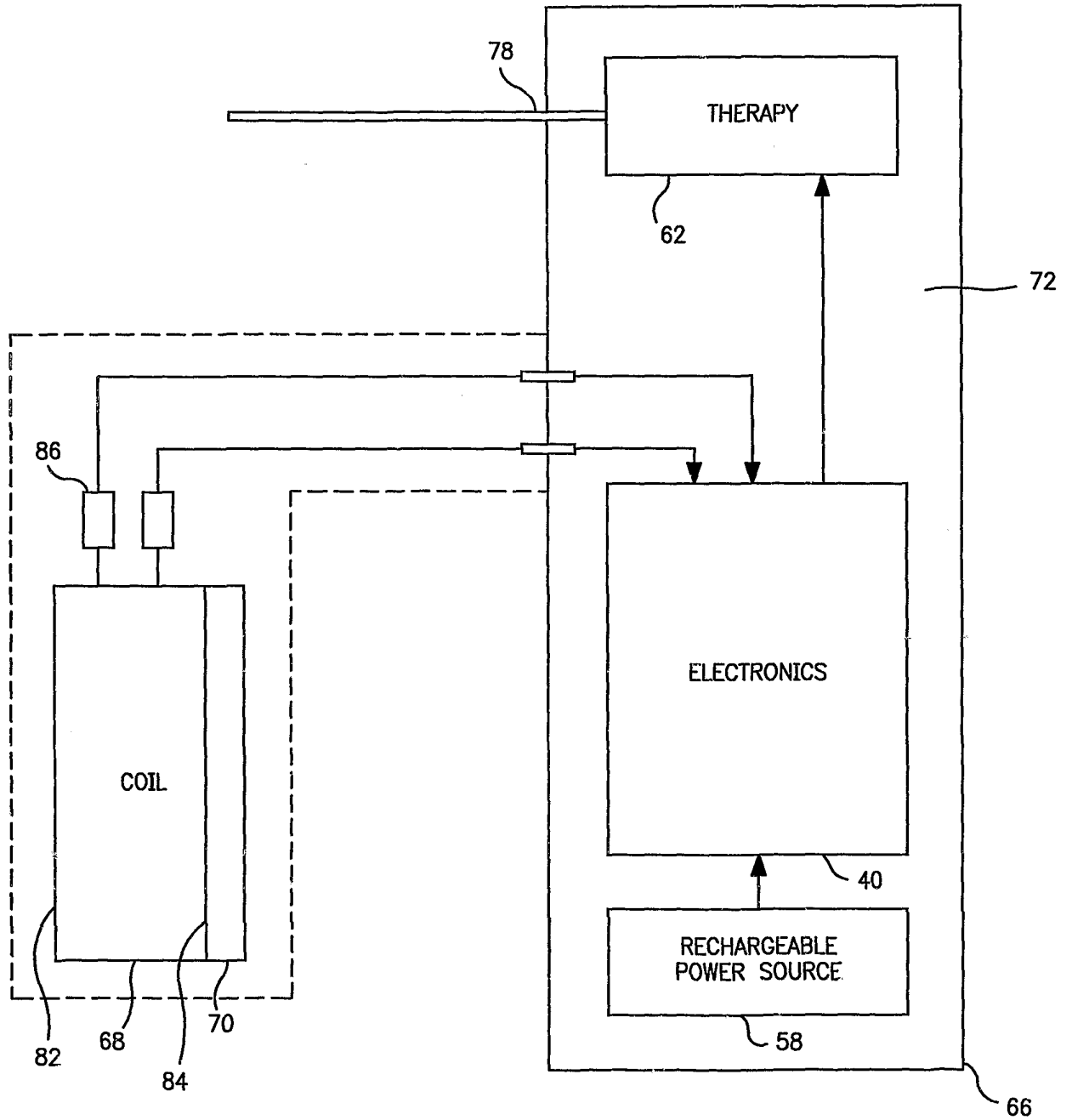

FIG. 4c

7/14

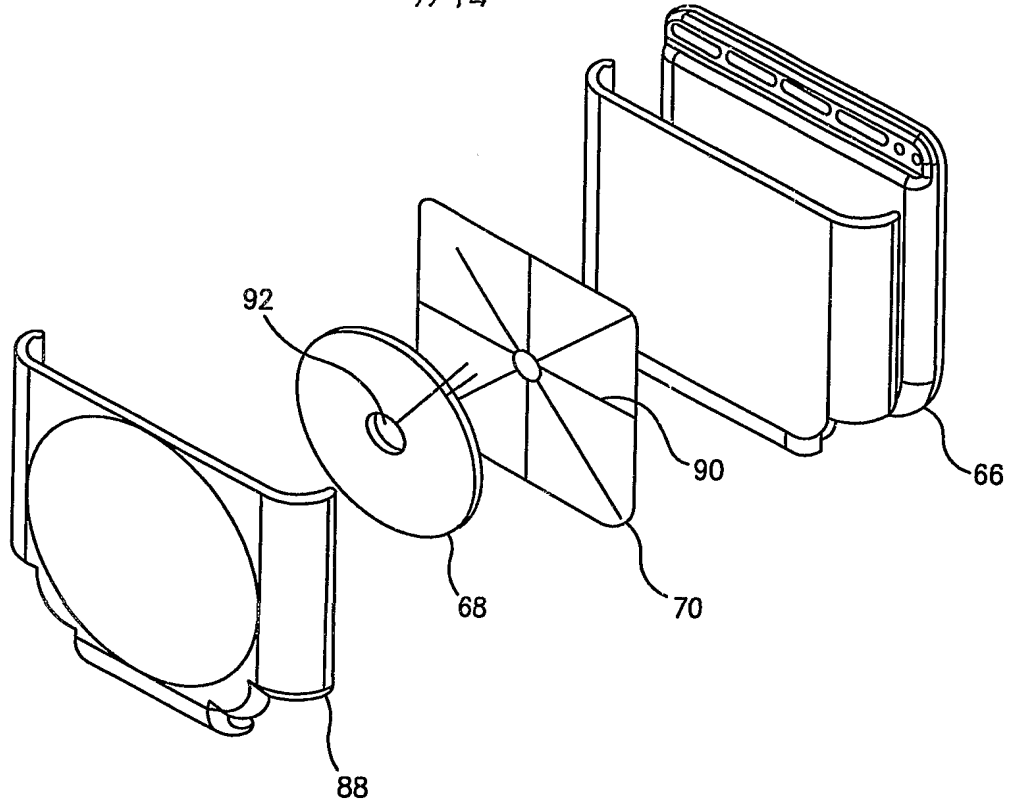

FIG. 5

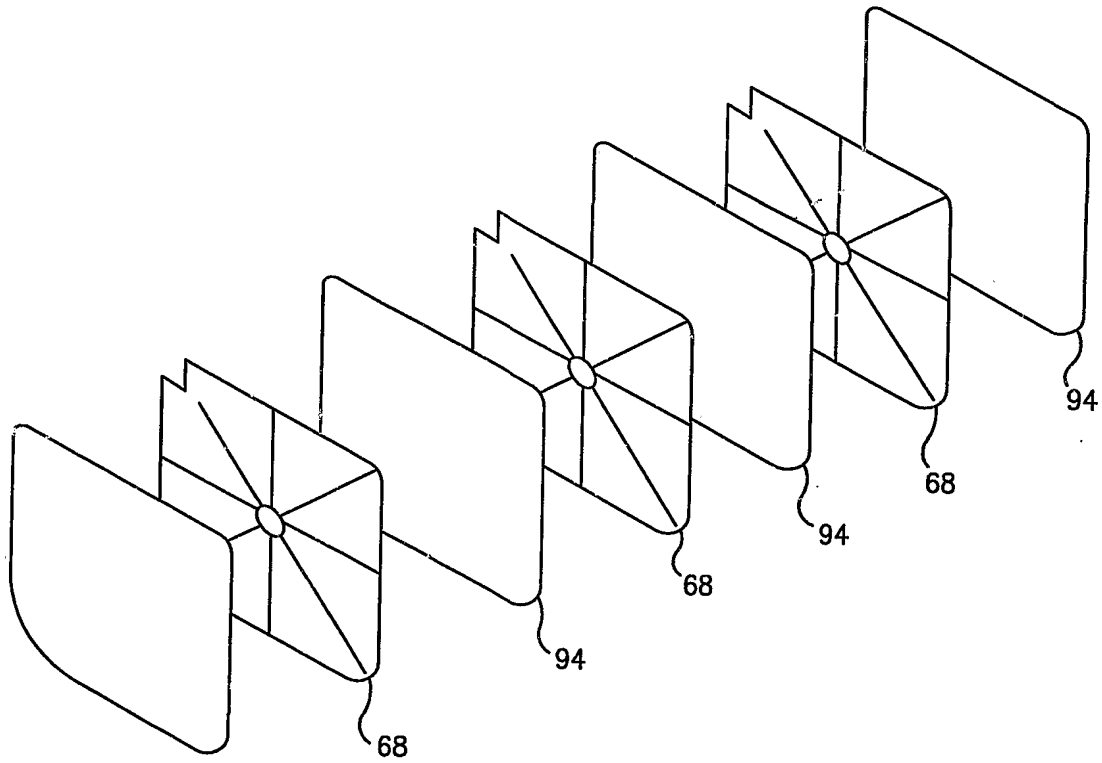

FIG. 6

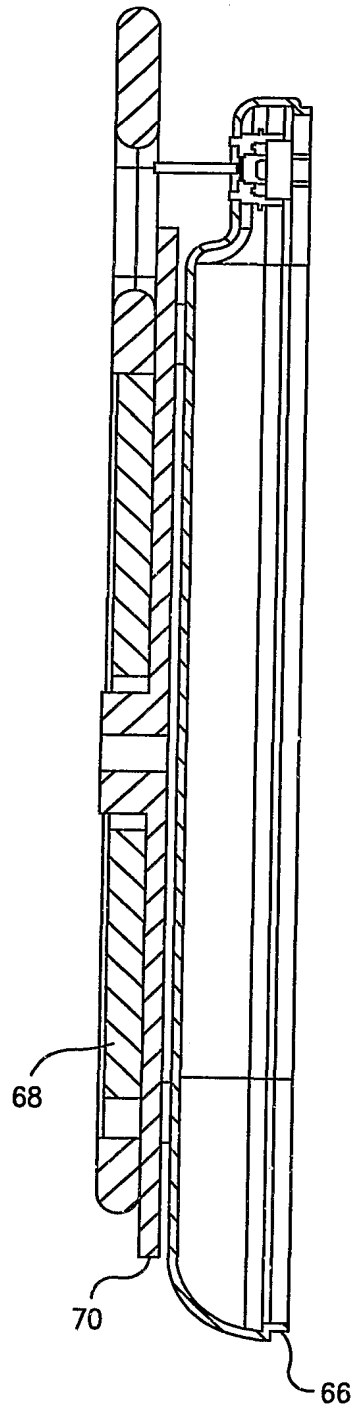

FIG. 7

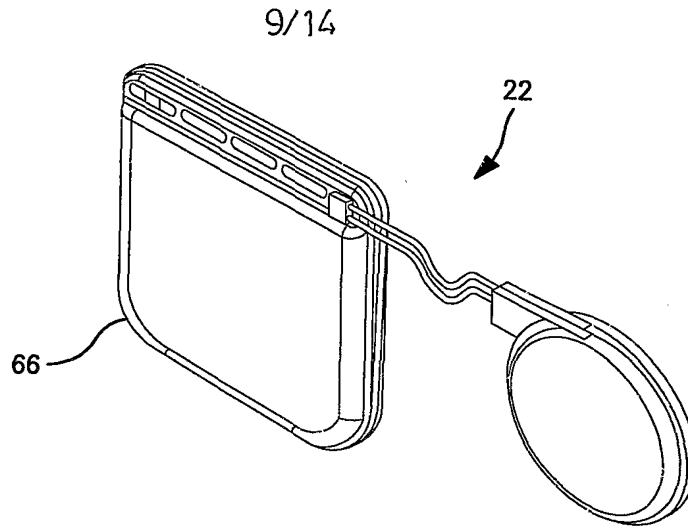

FIG. 8a

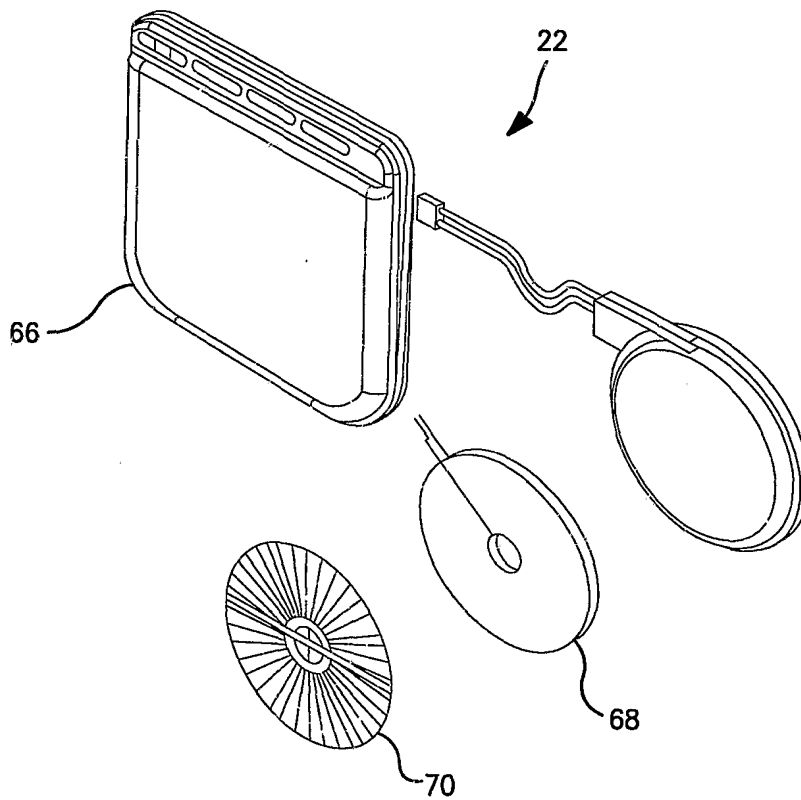

FIG. 8b



10/14

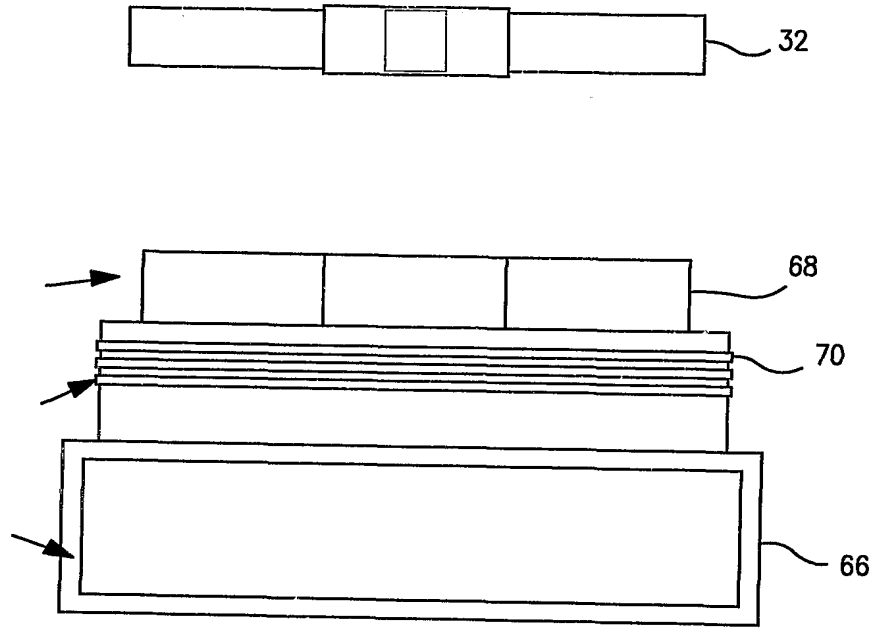

FIG. 9a

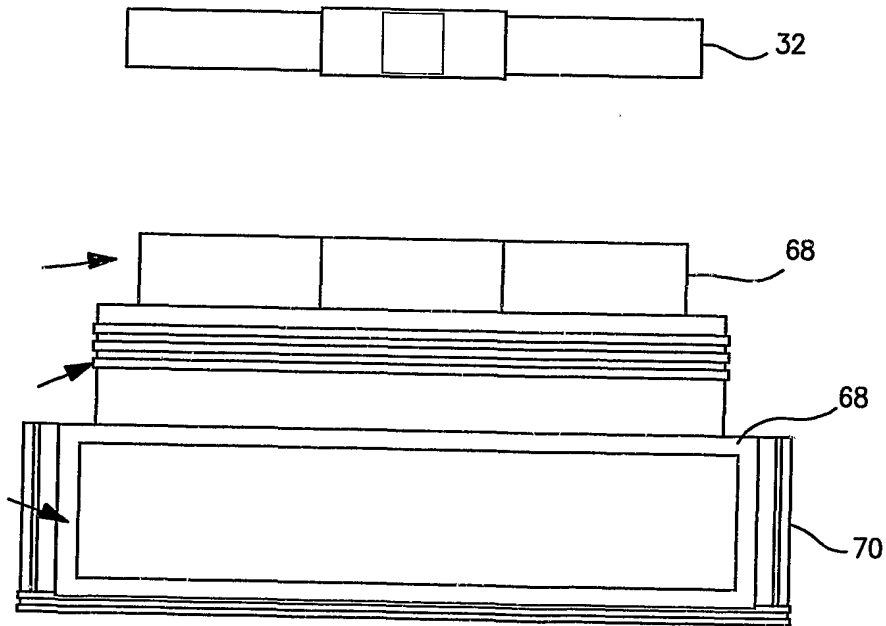

FIG. 9b

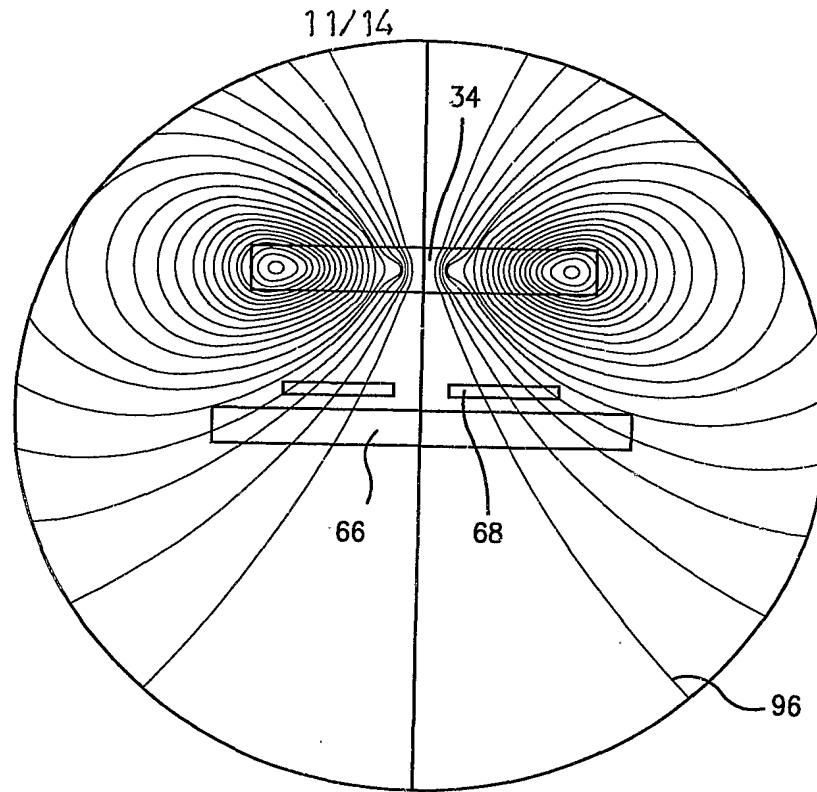

FIG. 10a

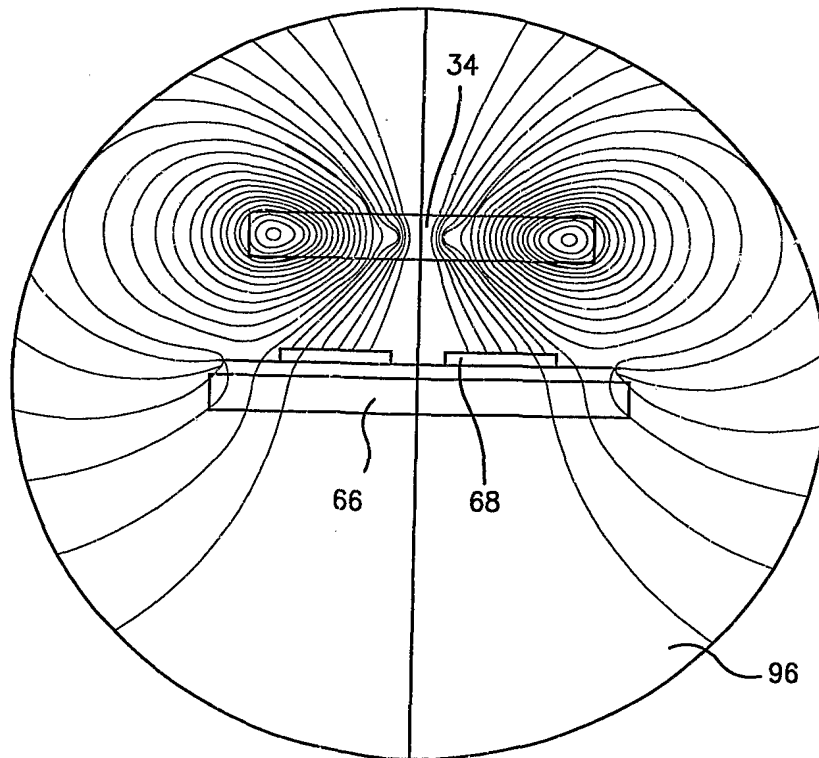

FIG. 10b

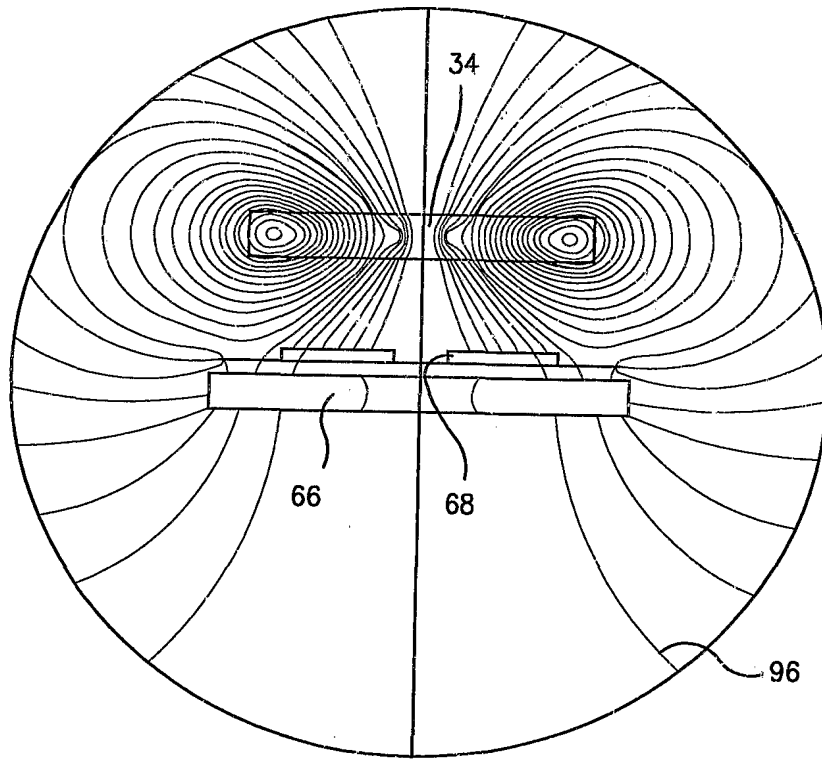

FIG. 10c

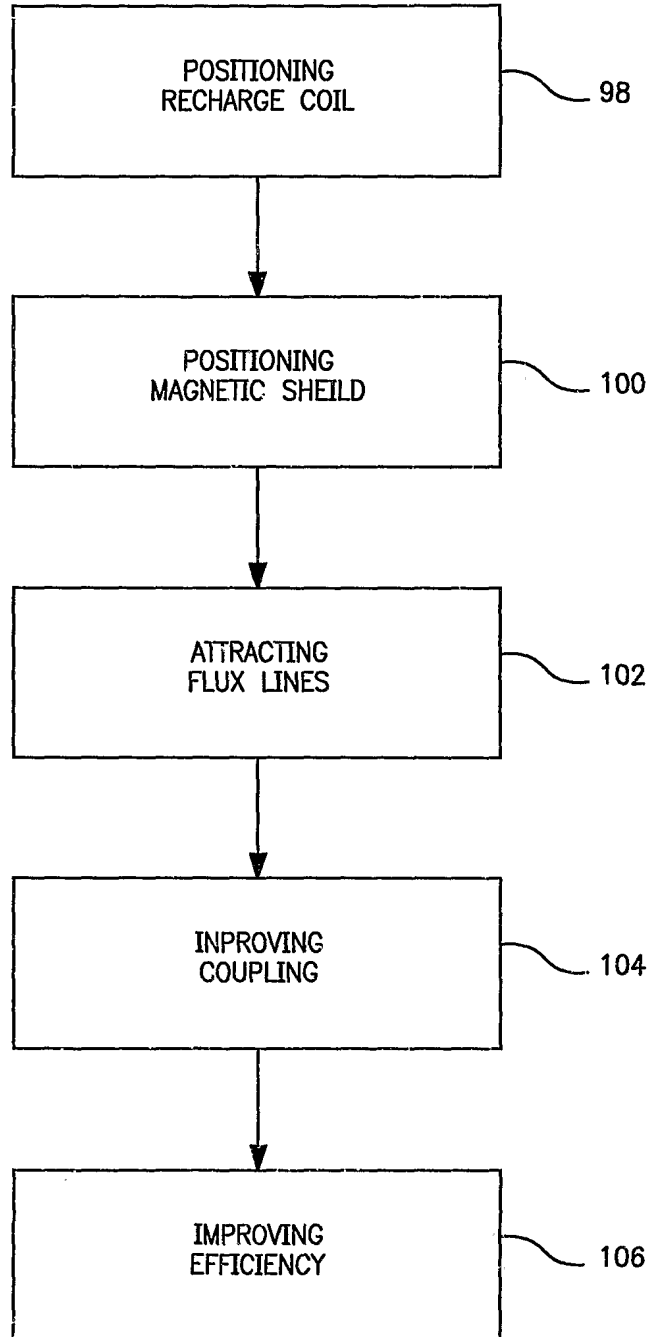
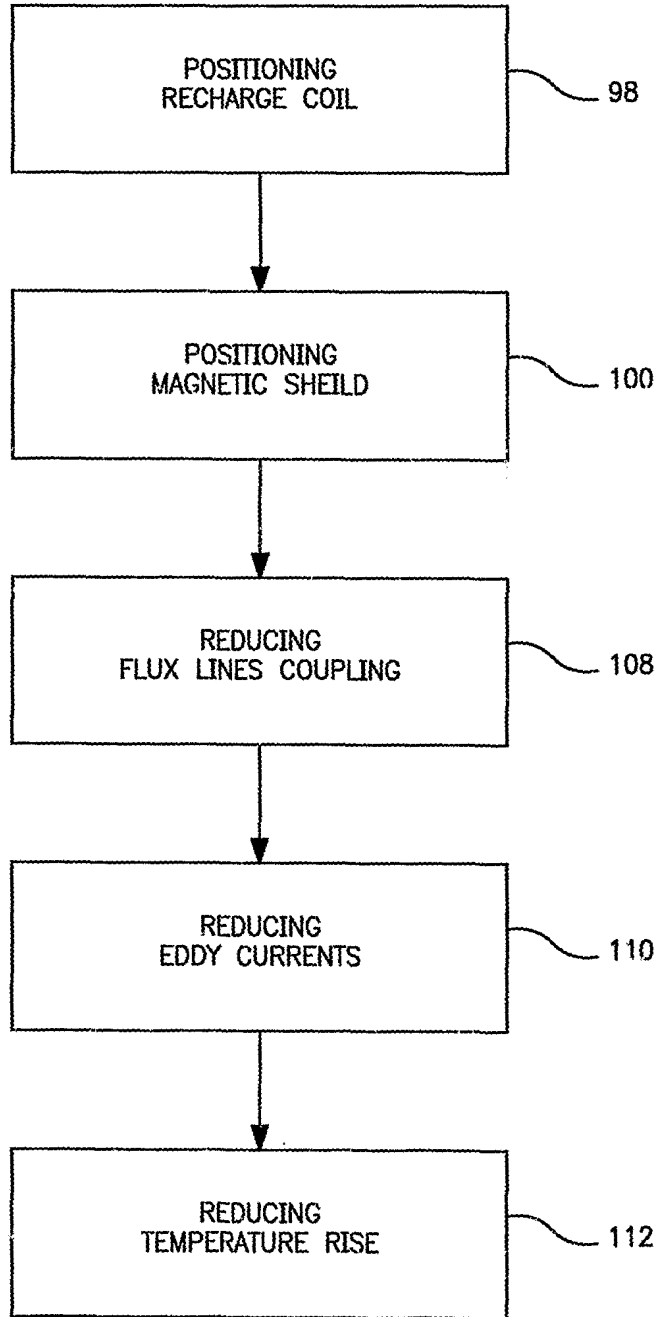

FIG. 11

14/14



**FIG. 12**